

DISASSEMBLY

1. w/o Power Window:

REMOVE REGULATOR HANDLE

Pull off the snap ring with a shop rag and remove the regulator handle and plate.

HINT:

At the time of assembly, please refer to the following item. With the door window fully closed, install the plate and the regulator handle with the snap ring.

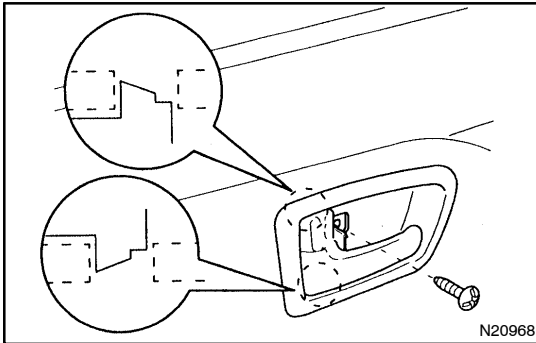

2. REMOVE INSIDE HANDLE BEZEL

- (a) Using a screwdriver, pry open the screw cover and remove the screw.

HINT:

Tape the screwdriver tip before use.

- (b) Using a screwdriver, pry out the bezel.

HINT:

Tape the screwdriver tip before use.

3. REMOVE FRONT WINDOW UPPER GARNISH

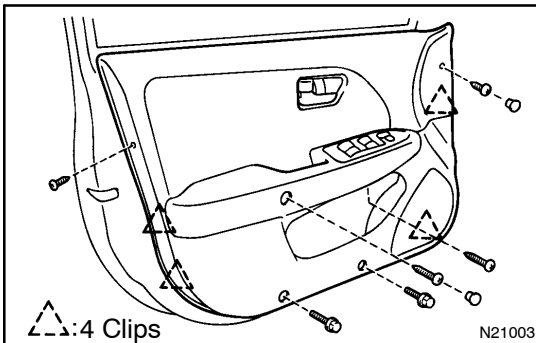

4. REMOVE DOOR TRIM

- (a) Using a screwdriver, remove the screw caps.

HINT:

Tape the screwdriver tip before use.

- (b) Remove the 2 clips, 2 screws and 2 bolts.

- (c) Insert a screwdriver between the door and door trim to pry out.

- (d) Pull the trim upward to remove it, then remove the power window switch and disconnect the harness connector.

5. REMOVE THESE PARTS:

- (a) Outside rear view mirror

Torque: 5.5 N·m (55 kgf·cm, 49 in·lbf)

- (b) Speaker

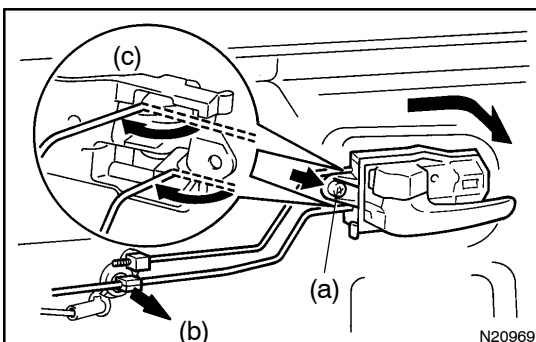

6. REMOVE DOOR INSIDE HANDLE

- (a) Remove the screw and pull the handle forward.

Torque: 3.5 N·m (35 kgf·cm, 31 in·lbf)

- (b) Remove the link from the clamp.

- (c) Remove the inside handle from the ends of the 2 links.

7. REMOVE SERVICE HOLE COVER

Remove the grommet, then remove the service hole cover.

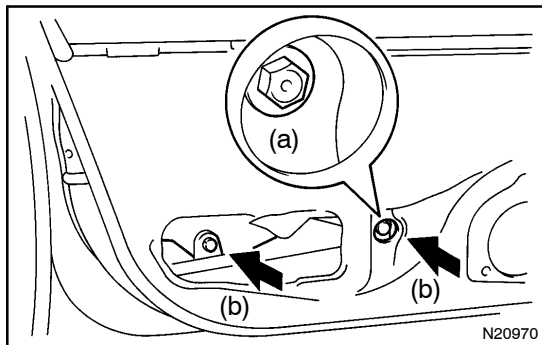
**8. REMOVE DOOR GLASS**

(a) Open the door glass until the bolt appears in the service hole.

(b) Remove the 2 bolts and the door glass.

HINT:

Pull the glass upward.

Torque: 8.0 N·m (80 kgf·cm, 71 in·lbf)

9. REMOVE GLASS RUN

HINT:

Pull the glass run upward.

10. REMOVE FRONT AND REAR SIDE FRAMES

Remove the 2 bolts, 2 nuts and the side frames.

HINT:

Remove the side frames through the service hole.

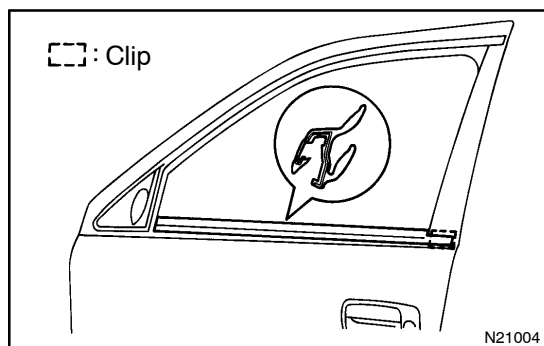
**11. REMOVE FRONT DOOR BELT MOULDING**

Pry the rearward end of the front door belt moulding from the door and remove the moulding.

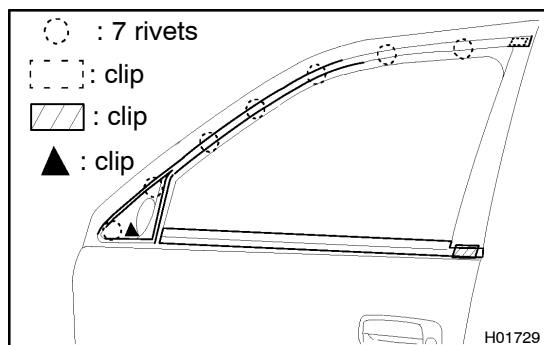
**12. REMOVE FRONT DOOR UPPER MOULDING**

(a) Using a drill, cut the flange portion of the 7 rivets.

HINT:

At the time of assembly, please refer to the following item.

Use 7 new rivets.

(b) Pry out the 2 clips and remove the moulding.

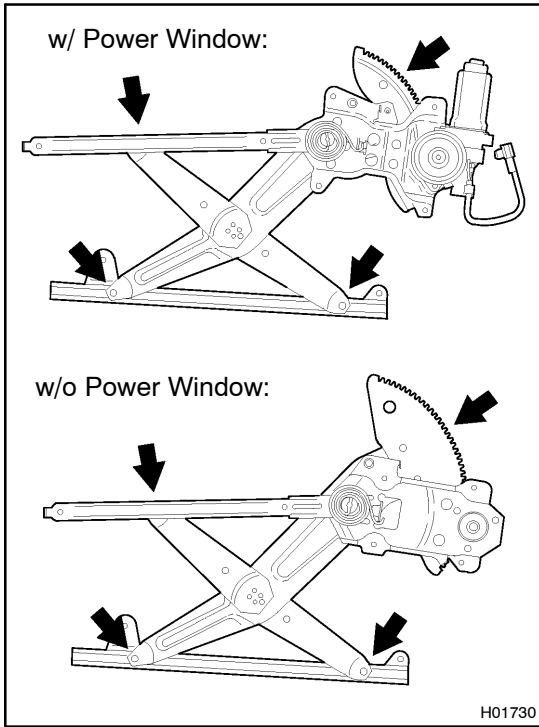

13. REMOVE WINDOW REGULATOR ASSEMBLY

Remove the bolts and window regulator.

Torque: 5.5 N·m (55 kgf·cm, 49 in·lbf)

HINT:

At the time of reassembly, please refer to the following item.
Apply MP grease to the window regulator rollers.

14. w/ Power Window:

REMOVE MOTOR FROM WINDOW REGULATOR

Remove the 3 screws and motor.

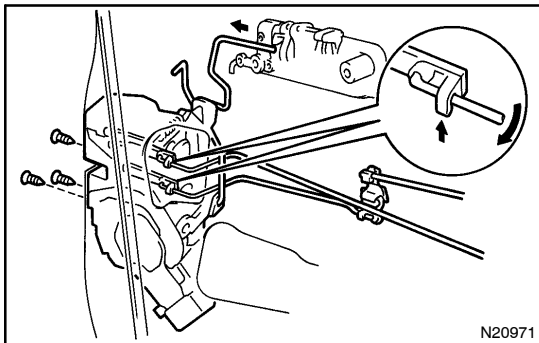

15. REMOVE DOOR LOCK

- (a) Remove the 2 clips.
- (b) Disconnect the 2 links from the door lock and remove the links.
- (c) Disconnect the 2 links from the outside handle and the lock cylinder.
- (d) Remove the 3 screws and door lock.

HINT:

At the time of reassembly, please refer to the following item.
Apply adhesive to 3 screws.

Part No. 08833-00070, THREE BOND 1324 or equivalent

Torque: 5.0 N·m (50 kgf·cm, 43 in·lbf)

- (e) w/ Power Door Lock:
Disconnect the connector.
- (f) Remove the door lock through the service hole.

HINT:

At the time of reassembly, please refer to the following item.
Apply MP grease to the sliding surface of the door lock.

16. REMOVE OUTSIDE HANDLE

Torque: 7.0 N·m (70 kgf·cm, 61 in·lbf)

